



Socket Weld Street Elbow

Specification: Socket Weld ends per ASME B16.11

Material: Available in a complete range of Carbon Steels, Stainless Steels, Alloy Steels and Non-ferrous metals certified to ASTM, ASME, and Military standards.

Sizes: 1/8" - 2" in Class 3000 • 1/8" - 1-1/2" in Class 6000
Also available in reducing pipe sizes and tube sizes

Socket Weld Pressure Class	Pipe Schedule
Class 3000	S80/XH
Class 6000	S160

Welding Gap and Minimum Flat Dimension for Socket Weld Fittings

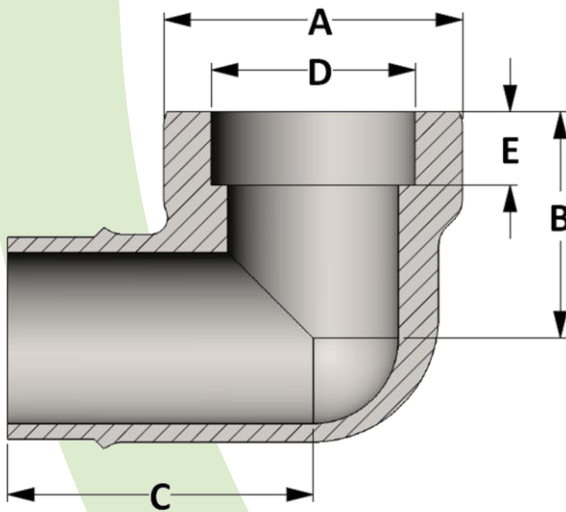
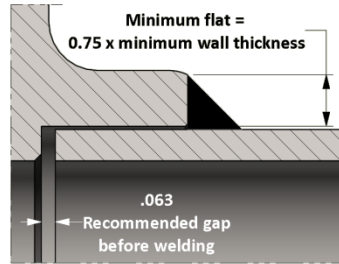

Active
3D
Model

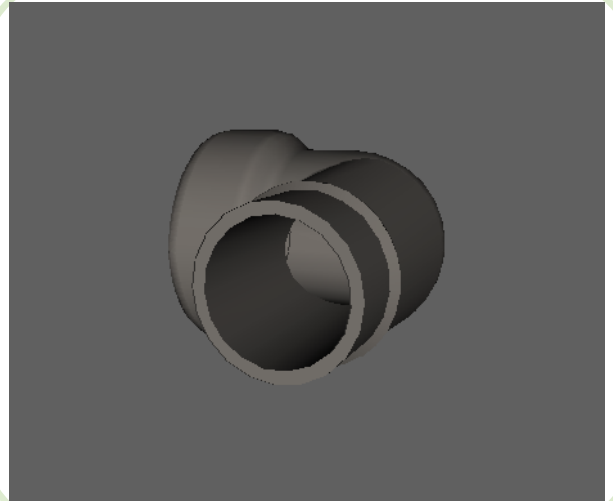

All dimensions are in inches • Weights are based on Carbon Steel

CLASS 3000 – Figure No. 13005

PIPE SIZE	1/8	1/4	3/8	1/2	3/4	1	1-1/4	1-1/2	2
A	1.000	1.000	1.313	1.500	1.750	2.000	2.438	2.750	3.313
B	0.875	0.875	1.125	1.250	1.375	1.750	2.000	2.125	2.500
C	1.250	1.250	1.500	1.688	1.875	2.250	2.625	2.875	3.313
D	0.426	0.560	0.693	0.859	1.071	1.335	1.682	1.922	2.410
E	0.438	0.438	0.438	0.500	0.563	0.625	0.688	0.750	0.875
LBS	0.21	0.19	0.39	0.55	0.85	1.40	2.05	2.55	4.30

CLASS 6000 – Figure No. 16005

PIPE SIZE	1/8	1/4	3/8	1/2	3/4	1	1-1/4	1-1/2	2
A	1.000	1.313	1.500	1.750	2.000	2.438	2.750	3.313	---
B	0.875	1.125	1.250	1.375	1.750	2.000	2.125	2.500	---
C	1.250	1.500	1.688	1.875	2.250	2.625	2.875	3.313	---
D	0.426	0.560	0.693	0.859	1.071	1.335	1.682	1.922	---
E	0.438	0.438	0.500	0.563	0.625	0.688	0.750	0.875	---
LBS	0.23	0.45	0.67	1.02	1.80	2.90	3.55	6.57	---