



# Butt Weld Tee

**Specification:** Dimensions per ASME B16.9  
Weld bevels per ASME B16.25

**Material:** Available in a complete range of Carbon Steels, Stainless Steels, Alloy Steels and Non-ferrous metals certified to ASTM, ASME, and Military standards.

**Sizes:** 1/2" – 4" in all Schedules

Also available in reducing sizes starting at 1/8" and in other requirements such as special wall thickness

All butt weld tees have been proof tested according to B16.9

## Butt Weld Ends Details

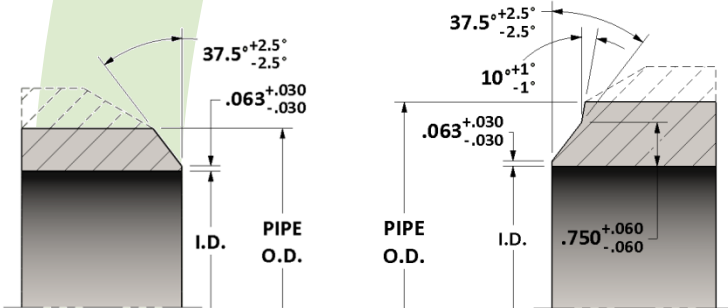

Weld bevels for wall thickness below 0.880"

Weld bevels for wall thickness above 0.880"

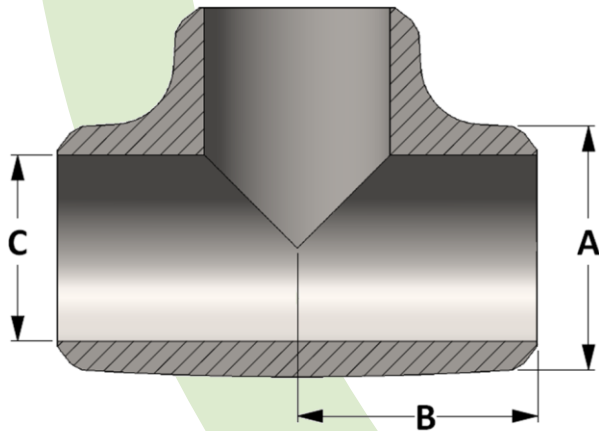

Active  
3D  
Model



All dimensions are in inches • Weights are based on Carbon Steel

PIPE SIZE	A	B	STD/S40		XH/S80		S160		XXH	
			C	LBS	C	LBS	C	LBS	C	LBS
1/2	0.875	1.000	0.622	0.24	0.546	0.28	0.464	0.32	0.252	0.38
3/4	1.063	1.120	0.824	0.34	0.742	0.41	0.612	0.50	0.434	0.59
1	1.375	1.500	1.049	0.71	0.957	0.85	0.815	1.04	0.599	1.24
1-1/4	1.660	1.880	1.380	1.17	1.278	1.43	1.160	1.70	0.896	2.18
1-1/2	1.900	2.250	1.610	1.71	1.500	2.11	1.338	2.65	1.100	3.28
2	2.375	2.500	2.067	2.43	1.939	3.08	1.689	4.21	1.503	4.91
2-1/2	2.875	3.000	2.469	5.83	2.323	6.88	2.125	8.17	1.771	10.08
3	3.500	3.380	3.068	8.46	2.900	10.12	2.624	12.59	2.300	15.004
4	4.500	4.120	4.026	14.33	3.826	17.48	3.438	22.97	3.152	26.49