

# Threaded Union 90° Elbow

ISO 9001 & PED Certified  
Canadian Registered in all provinces

**Material:** Available in a complete range of Carbon Steels, Stainless Steels, Alloy Steels and Non-ferrous metals certified to ASTM, ASME, and Military standards.

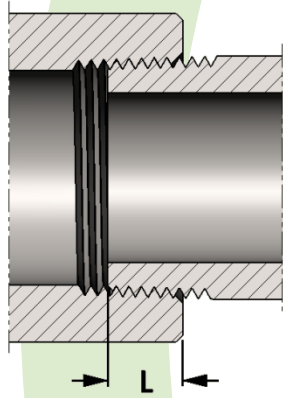

SIZE	L	SIZE	L
1/8	0.273	2	0.697
1/4	0.395	2-1/2	0.933
3/8	0.407	3	1.016
1/2	0.534	3-1/2	1.071
3/4	0.553	4	1.094
1	0.661	5	1.187
1-1/4	0.681	6	1.208
1-1/2	0.681	8	1.313

**Length of thread  
screwed into fitting**

**Sizes:** 1/8" - 3" in CL 3000

Also available in CL 2000, CL 6000, CL 9000 and CL 10,000 and in reducing pipe sizes.

**Threads:** American National Standard Taper Pipe Threads NPT (ANSI/ASME B1.20.1-1983)

Also available in other thread forms: NPTF, NPSC, NPSM, NGT, SAE, BSPT, BSPP and in any combination. Left hand threads available upon request.

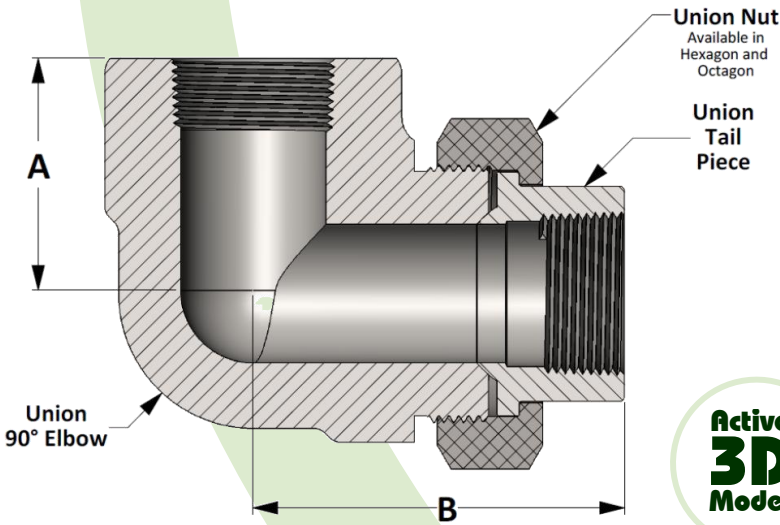

**Active  
3D  
Model**

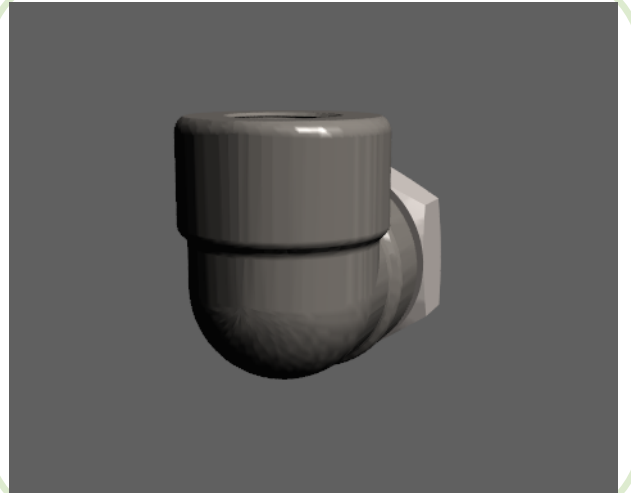

All dimensions are in inches • Weights are based on Carbon Steel

Class 3000 - Figure No. 03059											
PIPE SIZE	1/8	1/4	3/8	1/2	3/4	1	1-1/4	1-1/2	2	2-1/2	3
A	1.125	1.125	1.125	1.313	1.500	1.750	2.375	2.375	3.000	3.750	4.188
B	1.938	1.938	2.031	2.281	2.563	2.969	3.813	3.813	4.750	5.866	6.406
LBS	0.96	0.94	0.98	1.30	1.90	3.00	3.88	6.63	8.13	22.50	27.20